



EQUIPMENT

POWER-CHEF COMBINATION MICROWAVE OVEN COM-3400



STANDARD FEATURES

- Can defrost, cook, and bake food in one step, holds up to 100 programs
- Intelligent, energy saving programming procedure. Very easy to use
- Multispeed 3300 Watt convection with a 1000 Watt output power
- Ventless design eliminates the need for a dust hood
- Accommodates metal pans up to 280mm x 290mm x 150mm and 12" pizza stones
- Compact, stackable size allows for countertop compatibility

Technical Data

Electrical specifications	230/50/1 (v/Hz/Ø)
Power	3300 Watts, 15 Amps
Controls	Front control pad
Housing/Material	Zinc coated epoxy painted carbon steel
Machine dimensions	700 mm x 570 mm x 435 mm (27.56" x 22.44" x 17.13")
Net weight	69 Kg (152.12 lbs)

Detail & Dimensions

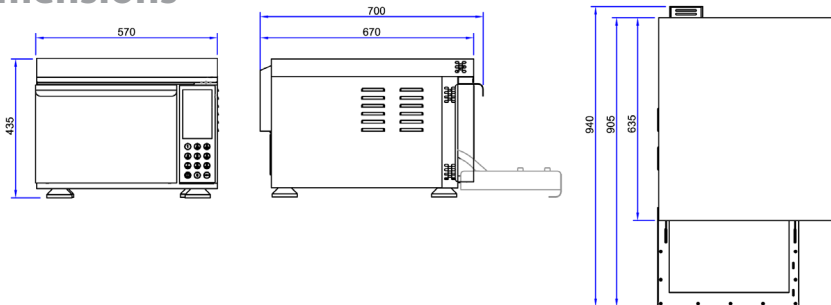

As continued product improvement is a policy of Powerline, specifications are subject to change without notice.



POWERLINE EQUIPMENT COMPANY

Pulaski Street, Norwalk, CT 06851 USA. Tel: 203-847 2357 Fax: 203-847 6480

www.powerlineequip.com