



EQUIPMENT

## WRAPPING MACHINE PW-460



### STANDARD FEATURES

- A simple and convenient wrapping machine used for keeping food fresh. Ideal for display, delivery, frozen and cold storage; extends freshness, prevents odors, and prevents contamination from dust and/or insects
- Stainless steel construction.
- Uses 17.7 wrapping film.
- Easy to use.
- Roll adjustment.

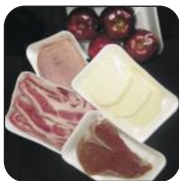

The hand wrapping machine PW-460 model allows for hygienic product presentation and keeps products dust - free.



### Practical and Portable

Practical light weight design to sit on a table and its indicator lights (power on, cutter and heated plate) alert the user about the elements.

### EQUIPMENT DIAGRAM

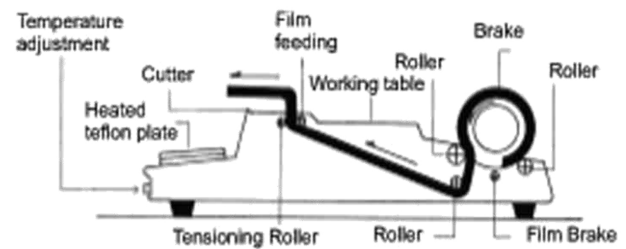

# WRAPPING MACHINE PW-460

## Technical Data

Dimension (LxWxH) in (mm)	18.9" x 23.62" x 5.12" (480 x 600 x 130)
Electric	220/60/1
Max width	450 mm or 17.72"
Temperature	70-130°C
Net weight	11.35 lbs. (5.15 Kg)
Construction	Stainless steel

## Detail & Dimensions

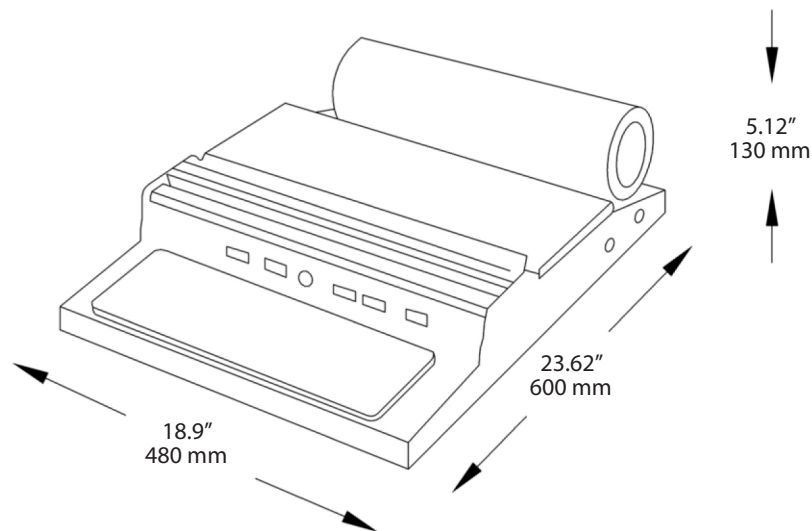

As continued product improvement is a policy of Powerline, specifications are subject to change without notice.



## POWERLINE EQUIPMENT COMPANY

Pulaski Street, Norwalk, CT 06851 USA. Tel: 203-847 2357 Fax: 203-847 6480

[www.powerlineequip.com](http://www.powerlineequip.com)