



EQUIPMENT

## MEAT & BONE SAW P120-3-SS



This P120-3 "SS" model is a more expensive top notch unit. This model features an all stainless steel construction: cabinet, head, and (sealed) motor compartment. It's ideally suited for fish processing plants, highly corrosion resistant even in a salt-water or high humidity environment. These machines can be dismantled for cleaning without tools, and can be hosed down whenever necessary. Known for its high volume meat processing in tough conditions. Additional features include precision balanced cast iron saw wheels to eliminate vibration, ensuring a steady blade drive & protection. Also, the easy slide system (fully stainless steel rollers) allow for a precise moving table ride, reducing effort and increasing productivity. Minimum maintenance, durable/ideal for continuous work and built to last.

### STANDARD FEATURES

- 3050 mm (120.08" x .5/8") saw blade
- Heavy duty, floor standing
- 3 HP motor 2.23Kw three phase
- Stainless steel body/construction
- Easy to clean: Hose down washable
- Friction resistant saw guides
- Waste tray
- Stainless steel fixed table



#### Tensioning system Easily adjustable

Assures a proper blade tension for a clean cut and a long lasting blade life.



#### Thermomagnetic switches

Protect the motor from overloads. Easily activated.



#### Removable wheel and blade cleaners system

To keep wheel and blade, grease and waste-free.

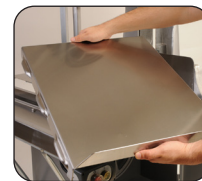

#### Disassembles easily

Main components are easily disassembled (Without tools) for cleaning and sanitizing, and saw blade can be replaced without the need to disassemble any of the components

# MEAT & BONE SAW P120-3-SS

## Technical Data

Saw blade (Inches)	3050 mm (120.08" x .5/8")
Blade speed	32 m/sec (104.99 ft/sec)
Throat width (Inches)	360 mm (14.17")
Throat height (Inches)	450 mm (17.72")
Table dimensions (WxL)	890 mm x 520 mm (35.04" x 20.47")
Switch type	Thermomagnetic
Finish	Stainless steel
Waste tray	Yes
Movable blade guard	Yes
Sealed off bearings	Yes
Non slip silent V-belt drive	Yes
Net weight (Shipping)	214 Kg (235 Kg) 471.79 lbs. (518.09 lbs.)
Voltage	220/50/3 or 380-440/50/60/3

## Detail & Dimensions

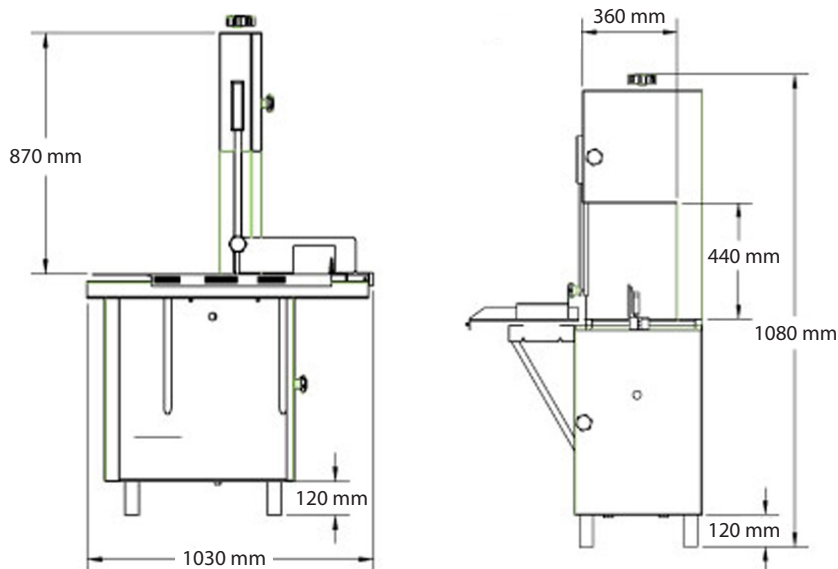

**NOM**



Safety & Sanitation  
Conforms UL  
std 763



Conforms  
NSF-8



Conforms CAN/CSA  
STD C22.2

As continued product improvement is a policy of Powerline, specifications are subject to change without notice.



## POWERLINE EQUIPMENT COMPANY

Pulaski Street, Norwalk, CT 06851 USA. Tel: 203-847 2357 Fax: 203-847 6480

[www.powerlineequip.com](http://www.powerlineequip.com)