

**INSTRUCTIONS FOR
OPERATION, SERVICE AND MAINTENANCE FOR
P-116-SS & P-116-3-SS
POWER LINE BAND SAW**

**INSTRUCTIONS FOR
OPERATION, SERVICE AND MAINTENANCE FOR
P-116-SS & P-116-3-SS
POWER LINE BAND SAW**

INTRODUCTION:

CONGRATULATIONS, YOU HAVE ACQUIRED A POWER LINE BAND SAW, WHICH IS MADE OF HIGH QUALITY LONG LASTING MATERIALS THAT SHOULD GIVE YOU YEARS OF TROUBLE FREE OPERATION AND DURABLE SERVICE. BEFORE YOU UNPACK YOUR NEW POWER LINE BAND SAW, **IT IS OF VITAL IMPORTANCE THAT YOU AND ANY PERSON THAT WILL OPERATE THIS UNIT THOROUGHLY READ THIS MANUAL.**

WARNINGS:

- THIS MACHINE IS DESIGNED TO CUT FOOD PRODUCTS AND IS BY NATURE DANGEROUS, IF NOT USED AND MAINTAINED PROPERLY FOR OPTIMUM SAFETY.
- DO NOT ALLOW UNTRAINED OR UNQUALIFIED PERSONNEL TO OPERATE THIS EQUIPMENT.
- NEVER PERFORM SERVICE, CLEANING OR MAINTENANCE ON THIS UNIT WHILE CONNECTED TO A POWER SOURCE.
- NEVER USE HANDS OR FINGERS TO FEED PRODUCTS TO CUT, OR INTRODUCE HANDS IN TO THE BLADE TRACK AREA, WITHIN 4" (FOUR INCHES) CLOSE TO THE BLADE, WHILE IN OPERATION.
- DO NOT LEAVE THE MACHINE UNATTENDED WHILE IN OPERATION

I - UNPACKING

1.- WHILE UNPACKING THE MACHINE TAKE SPECIAL CARE IN REMOVING THESE COM-

PONENTS AND MAKE SURE THAT ALL ARE ACCOUNTED FOR.

- 1 SPARE BAND SAW (6) *
- 1 SPARE FIBER GUIDE (17)
- 1 SCRAP PAN (26)
- 1 CARRIAGE (8)
- 1 TABLE ASSY.(5)
- 1 LAST CUT PUSHER (36)

***NOTE:** FOR REFERENCE NUMBERS SEE **FIG-6.**

II. INSTALLATION:

BEFORE CONNECTING TO THE POWER SOURCE FOLLOW THESE EASY ASSEMBLY AND PREPARATION STEPS. (NEVER EXECUTE THESE PROCEDURES WITH THE CORD PLUGGED TO THE POWER SOURCE).

- 1.- SET THE SAW ON A CLEAN AND LEVEL FLOOR, USING THE LEVELING LEGS.(28)
- 2.- BE SURE THAT THE WHEELS (2 & 25) AND BLADE (6) RUN FREE OF OBJECTS.
- 3.- WE SUGGEST TO REMOVE THE BLADE (6) TO FACILITATE THE ASSEMBLY OF THE TABLE (5), TO DO THIS, FOLLOW THIS EASY STEPS.
 - A.- OPEN THE HEAD DOOR (19) AND THE LOWER (RIGHT) DOOR (23).
 - B.- ROTATE-UP THE FIBER GUIDE (17).(**SEE FIG. 1**).

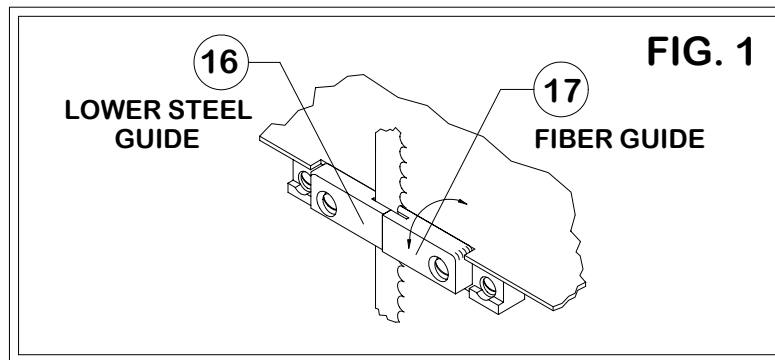

- C.- TURN THE TENSION HANDLE (18) COUNTER CLOCK WISE, UNTIL BLADE (6) IS LOOSE.
 - D.- PULL OUT THE BLADE FROM THE WHEELS (2 & 25) GUIDES (15, 16 & 17) AND SCRAPERS (20).
- 4.- INSTALL THE TABLE ASSY. (5), FOLLOWING THESE STEPS (**SEE FIG. 2**):

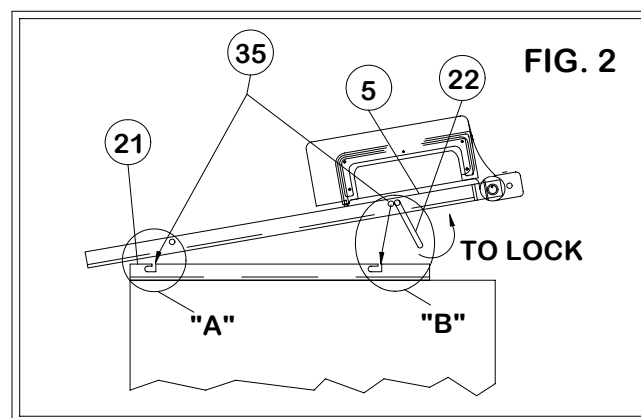

- A.- BE SURE THAT THE HEAD DOOR (19) AND THE RIGHT DOOR (23) ARE STILL OPEN.
 - B.- CAREFULLY TAKE THE TABLE ASSY. (5), PLACE IT ON THE TABLE BASE (21).
 - C.- FIRST PUT ONE ROD ON THE BASE-SLOT AS SHOWN ON DETAIL " A ", THEN PUT THE OTHER ROD, ON THE OTHER SLOT AS SHOWN ON DETAIL " B ". **AS ILLUSTRATED FIG 2**
 - D.- ASSURE THE RODS OF THE TABLE ASSY. (35) FIRMLY INTO THE SLOTS OF THE TABLE BASE (21).

E.- TURN THE HANDLE (22) UNDER THE TABLE (TOWARDS YOU), TO LOCK THE TABLE ASSY.(5).

5.- INSTALL THE CARRIAGE (8) ON ITS GUIDE (27), THE STEPS ARE AS FOLLOW (SEE FIG. 3)

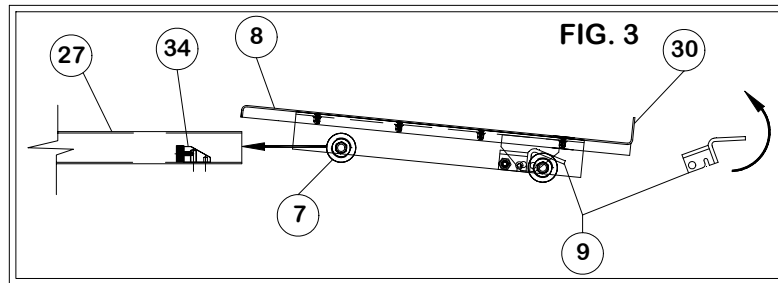

- A.- TAKE THE CARRIAGE (8) TO YOUR RIGHT.
- B.- GET THE LEFT WHEELS (7) CLOSE TO THE CARRIAGE GUIDE (27) AND ASSURE TO PUT BOTH WHEELS (7) IN TO THE GUIDE.
- C.- MOVE THE CARRIAGE (8) ALL THE WAY TO THE LEFT [THE CARRIAGE-LOCK (9)] WILL ENGAGED AUTOMATICALLY . **SHOWN ON FIG. 3**

6.- INSTALLING THE SAW BLADE (6).

- A.- BE SURE OF THE DIRECTION OF THE CUT (TEETH MUST FACE DOWN, SEE DETAIL " A " ON **FIG 7**).
- B.- PUT THE BLADE (6) ON THE WHEELS (2 & 25), INTO THE GUIDES (15,16 & 17) AND INTO THE SCRAPERS.(20).
- C.- TURN THE TENSION HANDLE (18) CLOCK WISE UNTIL THE RED SPOT (1) IS IN THE CENTER OF THE HOLE, OF THE TENSION GAUGE HOUSING.(31).
- D.- TURN THE UPPER WHEEL (2) COUNTER CLOCK WISE 2 OR 3 REVOLUTIONS BY HAND, **VERY SLOWLY AND WITH CAUTION** TO BE SURE EVERY THING IS OK.

NOTE: DO NOT OVER TIGHTEN THE BLADE, THE EXCESSIVE TENSION WILL CAUSE OVERHEAT AND THE BLADE MIGHT BRAKE WITH POTENTIAL PERSONAL INJURY.

7.- CLOSE ALL THE DOORS

8.- SELECT THE WORK PLACE, AND:

- A.- BE SURE THAT THE SURFACE IS LEVELED AND CLEAN.
- B.- CHECK AGAIN AND ASSURE THE SAW IS PERFECTLY LEVELED ON THE FLOOR [USE LEVELING LEGS (28)].

NOTE: CHECK THE POWER SOURCE OF YOUR FACILITY, AND BE SURE IT MATCHES THE REQUIREMENTS OF THE UNIT, THE VOLTAGE OF THE MOTOR CAN BE CHANGED BY A QUALIFIED ELECTRICIAN, TO DO THIS PLEASE CONTACT YOUR POWER LINE DEALER.

C.- CONNECT THE SAW TO THE POWER SOURCE (IT MUST BE CLOSE TO THE SAW).

WARNING:

**NEVER OPERATE THE MACHINE WITH THE DOORS OPEN
SERIOUS INJURY MAY HAPPEN**

III -OPERATION

IMPORTANT: FOR THE FIRST TIME USAGE YOU MUST CUT A COUPLE OF POUNDS OF SCRAP CLEAN PRODUCT TO CLEAN THE BLADE (6) OF ANY DIRT OR FOREIGN DEBRIS.

NORMAL OPERATION OF THE SAW:

THE NORMAL STEPS TO OPERATE THE SAW ARE AS FOLLOWS.

- 1.- SELECT THE THICKENS OF CUT, USING THE GAUGE PLATE ASSY (11).
- 2.- PUT THE PRODUCT ON THE CARRIAGE (8)
- 3.-TURN ON THE MACHINE (**DO NOT LEAVE MACHINE UNATTENDED WHILE IN OPERATION**).

YOUR SAW COMES EQUIPPED WITH THE THERMOMAGNETIC TRIPLE PHASE SWITCH BOX,(WHICH IS THE SAME FOR SINGLE PHASE) PRESS THE GREEN BUTTON TO START AND THE RED BUTTON TO TURN OFF THE POWER.

- 4.- PLACING THE PRODUCT AGAINST THE GAUGE PLATE (11) YOU CAN START TO CUT, IT IS RECOMMENDED TO WORK FRONT FACE TO THE GAUGE PLATE,**ONCE AGAIN ,NEVER PUT YOUR HANDS OR FINGERS CLOSE TO THE BLADE,SERIOUS PERSONAL INJURY MAY HAPPEN.**
- 5.- YOU MAY START TO CUT THE PRODUCT.

NOTE: IF YOU WANT TO LOCK THE CARRIAGE, TO KEEP IT FIXED IN ONE POSITION (**WITH NO MOVEMENT**) YOU MAY USE THE KNOB UNDER THE CARRIAGE (33)

IV -KEY ELEMENTS IN CUTTING QUALITY PRODUCT:

- 1.- DO NOT FORCE THE CUT AGAINST THE BLADE (6).
- 2.- BE SURE OF USING ALWAYS SHARP SAW BLADES.
TO KNOW IF YOU ARE STILL USING A SHARP BLADE, PAY ATTENTION TO THE FEEL OF THE CUT. IF YOU HAVE TO FORCE FEED THE PRODUCT TO CUT INTO THE BLADE THEN YOU NEED A NEW SHARP BLADE, IF THE CUT FEELS SMOOTH AND WITHOUT MUCH EFFORT THEN YOUR BLADE IS STILL OK.

NOTE: IF YOU NEED TO REPLACE IT, FOLLOW THE PROCEDURE DESCRIBED ON SECTION II: INSTALLATION (STEPS 3 AND 6)

- 3.- KEEP CLEAN AND FREE OF ANY PRODUCT OR SCRAP, THE GUIDES (15, 16 & 17), WHEELS (2 & 25) AND CLEANERS (20), **NEVER ATTEMPT ANY CLEANING WHILE THE MACHINE IS CONNECTED TO THE POWER SOURCE.**

NOTE: IT IS NOT RECOMMENDED TO USE RE-SHARPENED BLADES BECAUSE YOU WILL CREATE MORE SCRAP IN YOUR PRODUCT. AND HAVE A LESS EFFICIENT OPERATION.

V -CLEANING:

WARNING

ALWAYS UNPLUG OR DISCONNECT THE MACHINE FROM THE POWER SOURCE BEFORE ATTEMPTING CLEANING OR SERVICE.

NOTE: IT IS RECOMMENDED TO CLEAN THE MACHINE DAILY.

FOR THE DAILY CLEANING REMOVE ALL THE SCRAP OF THE MACHINE WITH THE SCRAP PAN AND A BRUSH AND THEN WASH DOWN THE MACHINE, **YOU CAN USE A WATER HOSE FOR A BETTER AND DEEPER CLEANING.**

ALSO IT IS RECOMMENDED TO DO AT LEAST ONCE A WEEK A MORE THROUGH CLEANING FOLLOWING THIS PROCEDURE:

- 1.- REMOVE THE BLADE (STEPS 3 AND 6 ON SECTION II)
- 2.- REMOVE THE UPPER SCRAPER, JUST PULL IT TOWARDS YOU. ALSO REMOVE THE LOWER SCRAPER ASSEMBLIES BY LOOSENING THE KNOBS. TAKE THESE PARTS APART AND WASH WITH A SOFT BRUSH AND A MILD DETERGENT. RINSE THOROUGHLY AND RE-ASSEMBLE.
- 3.- HOLD THE UPPER WHEEL (2) WITH ONE HAND AND WITH YOUR OTHER HAND TURN THE TENSION HANDLE (18) COUNTER COLCK WISE UNTIL IS COMPLETELY OUT OF THE ROD.
- 4.- SLIDE THE UPPER WHEEL (2) DOWN, OUT OF THE TENSION GUIDES (32) AND REMOVE IT, **BE CAREFUL BECAUSE IT'S HEAVY AND IF IT FALLS MAY CAUSE A PERSONAL INJURY.**
- 5.- THE UPPER WHEEL (2) IS ASSEMBLED TO THE TENSION GAUGE ASSY. **(FIG.4).** DISASSEMBLE THE TENSION GUIDE ASSY. REMOVING THE TENSION GAUGE PIN (37) WITH YOUR HANDS. THIS WILL LET YOU TAKE OUT THE TENSION GAUGE HOUSING (31), TENSION GAUGE SPRING (39), THE ROD AN INDICATOR (1), AND THE UPPER WHEEL HANGER (38). CLEAN THESE PARTS USING A SOFT BRUSH AND A MILD DETERGENT, RINSE WITH WATER. ASSEMBLE AGAIN, REVERSING THE DISASSEMBLE ORDER, TAKING CARE THAT THE PAINTED SIDE OF THE ROD AND INDICATOR (1) FACE THE HOLE AT THE TENSION GAUGE HOUSING (31).

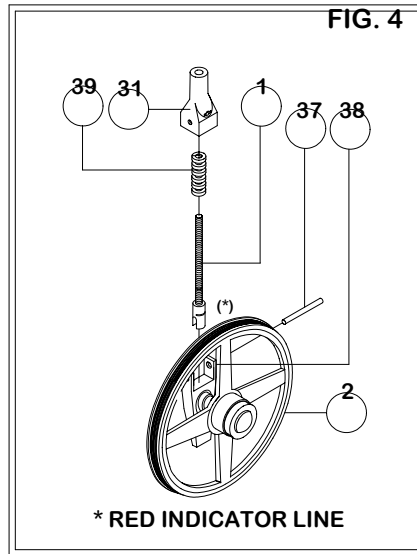

- 6.- MOVE THE CARRIAGE (8) TO YOUR RIGHT UNTIL STOP, THEN WITH YOUR FINGER, LIFT THE CARRIAGE-LOCK (9) AND SLIDE AGAIN TO YOUR RIGHT TO REMOVE THE CARRIAGE FROM IT'S GUIDE (**SEE FIG. 3**).
- 7.- FOLLOWING STEP 4 ON SECTION II BUT IN REVERSE REMOVE THE TABLE ASSY.
- 8.- NOW YOU CAN CLEAN THE SAW MORE EASILY. (WE RECOMMEND TO DO THIS AT LEAST ONCE A WEEK) **OR MORE OFTEN IF YOU WANT.**
- 9.-AFTER A VERY THOUGH CLEANING AND DRYING OF THE MACHINE AND ITS DISASSEMBLED COMPONENTS HAS BEEN DONE, PUT THEM BACK IN REVERSE ORDER FOLLOWING THE STEPS ON SECTION II .

VI - MAINTENANCE.

WARNING

ALWAYS DISCONNECT THE MACHINE FROM THE POWER SOURCE BEFORE EXECUTING ANY SERVICE OR MAINTENANCE.

- 1.- **BLADE:** AFTER CLEANING THE SAW, CHECK THE SHARPNESS OF THE BLADE,AS DESCRIBED ON SECTION IV (STEP 2) IF IT IS NOT SHARP REPLACE IT,FOLLOWING STEPS 3 & 6 ON SECTION II
- 2.- **FIBER GUIDE:** THE PURPOSE OF THIS GUIDE IS TO KEEP THE BLADE STRAIGHT TO HELP YOU IN THE CUT OF THE PRODUCT, IF YOU SEE THE BLADE IS NOT CUTTING IN A STRAIGHT PATH, OR YOU SEE THE CLEARANCE OF GROOVE IN THE FIBER GUIDE (17) TO BE MORE THAN 1/8 OF AN INCH, IT'S TIME TO REPLACE IT.
ALSO IT IS ADVISABLE TO REPLACE THIS COMPONENT AT LEAST ONCE EVERY 2 MONTHS DEPENDING ON WORK LOAD.
TO REPLACE THE FIBER GUIDE FOLLOW THESE STEPS AND SEE FIG 5:

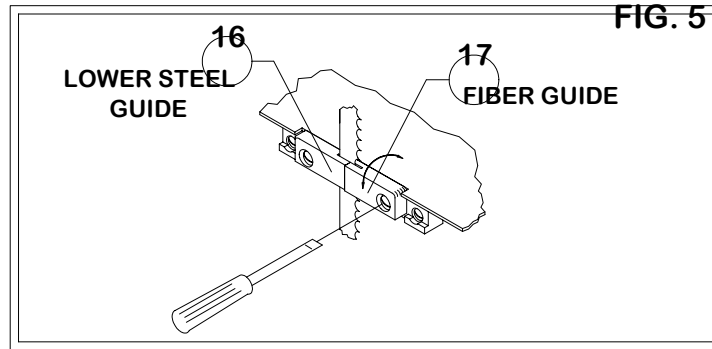

- A.- STOP THE MACHINE AND DISCONNECT FROM THE POWER SOURCE.
- B.- SLIDE THE CARRIAGE (8) ALL THE WAY TO THE LEFT.
- C.- WITH A SCREWDRIVER (4) REMOVE THE BOLT FROM IT'S PLACE AND REPLACE WITH A NEW FIBER GUIDE (2).

NOTE: IT IS RECOMENDED TO HAVE A POWER LINE DEALER TECHNICIAN DO A COMPLETE MAINTENANCE CHECK TO THIS MACHINE AT LEAST ONCE A YEAR.

THANK YOU FOR SPENDING THE TIME TO READ THIS MANUAL.
IF THERE ARE ANY QUESTIONS PLEASE CONTACT YOUR POWER LINE DEALER

FIGURE 6

PARTS LIST FOR SCHEMATICS (MODEL P-116-SS)

ITEM	DESCRIPTION	QTY
1	ROD & INDICATOR 1/2"	1
2	UPPER WHEEL	1
3	ADJUST SCREW	1
4	HEX NUT 3/8"	1
5	TABLE ASSY	1
6	BLADE	1
7	WHEEL	4
8	TABLE CARRIAGE	1
9	LOCK S.S	1
10	MOTOR 1.5HP 1PHASE (NOT SHOWN)	1
	MOTOR 3HP 3 PHASES (NOT SHOWN)	1
11	GAUGE PLATE ASSY	1
12	PUSH BUTTON BOX	1
13	POWER CORD (1PH or 3 PH)	1
14	PULLEY 4" (NOT SHOWN)	1
15	UPPER SAW GUIDE	1
16	LOWER GUIDE (STEEL)	1
17	FIBER GUIDE	1
18	TENSION HANDLE	1
19	HEAD DOOR	1
20	WHEEL SCRAPER (CLEANER)	1
21	TABLE BASE	1
22	HANDLE	1
23	LOWER DOOR (RIGHT)	1
24	SMALL PLATE	1

25	LOWER WHEEL	1
26	PAN	1
27	CARRIAGE GUIDE	1
28	LEVELING LEGS	4
29	SLIDING BAR	1
30	BLADE GUARD	1
31	TENSION GAUGE HOUSING	1
32	TENSION GUIDES	2
33	KNOB	1
34	STOP CARRIAGE BLOCK	2
35	TABLE ASSY RODS	2
36	LAST CUT PUSHER	1
37	TENSION GAUGE PIN	1
39	TENSION GAUGE SPRING	1
40	MICROSWITCH	2

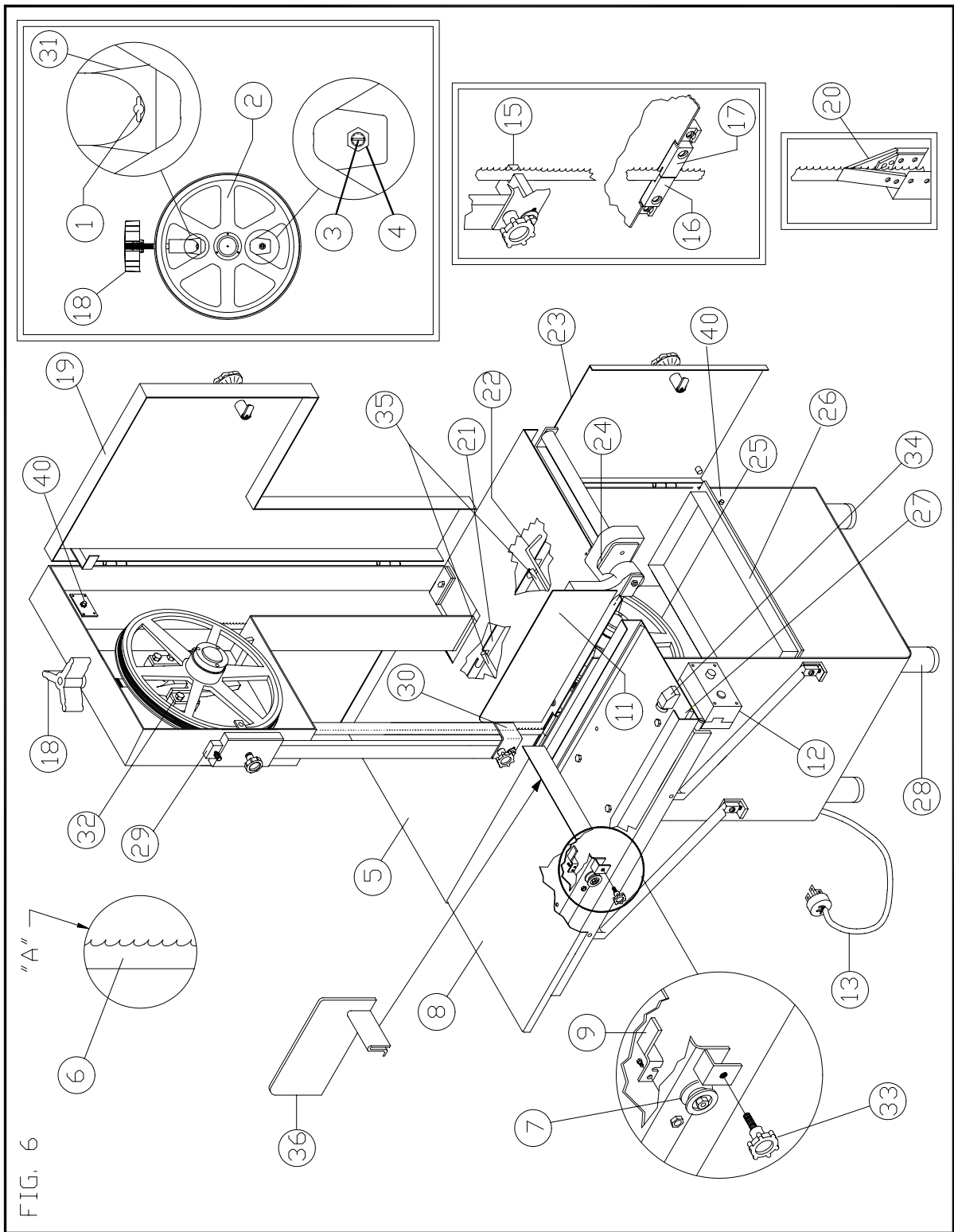

THANK YOU FOR SPENDING THE TIME TO READ THIS MANUAL.
 IF THERE ARE ANY QUESTIONS PLEASE CONTACT POWERLINE EQUIPMENT
WEB SITE: www.powerlineequip.com
Tel. No. (1-203) 847-2357
Fax. No. (1-203) 847-6480